

DN	Class	B	E	H	D	E	F	G	L	M	N	W	Gear	WEIGHT
3"	1500	650	74	345	71	70	130	200	290	340	260	300	AB550	230 Kg
2"	1500	540	49	300	52	52	100	182	225	320	240	200	AB215	93 Kg
3"	600	530	74	340	71	52	120	190	285	330	250	250	AB550	173 Kg
2"	600	440	49	295	52	45	100	160	225	300	220	200	AB215	70 Kg

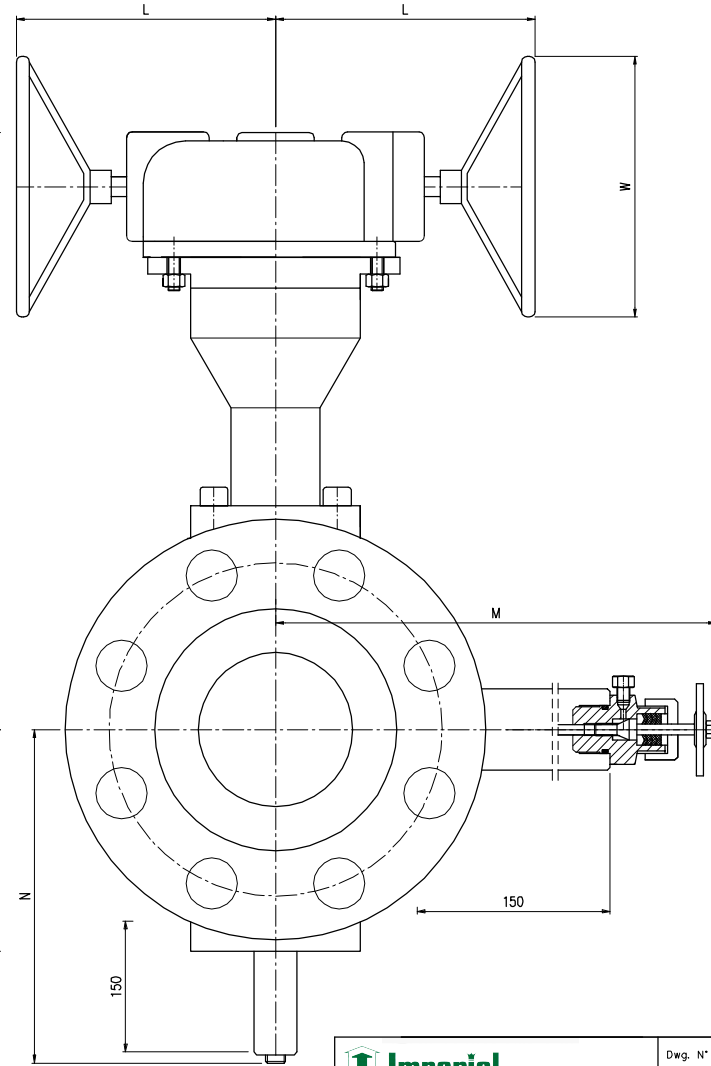
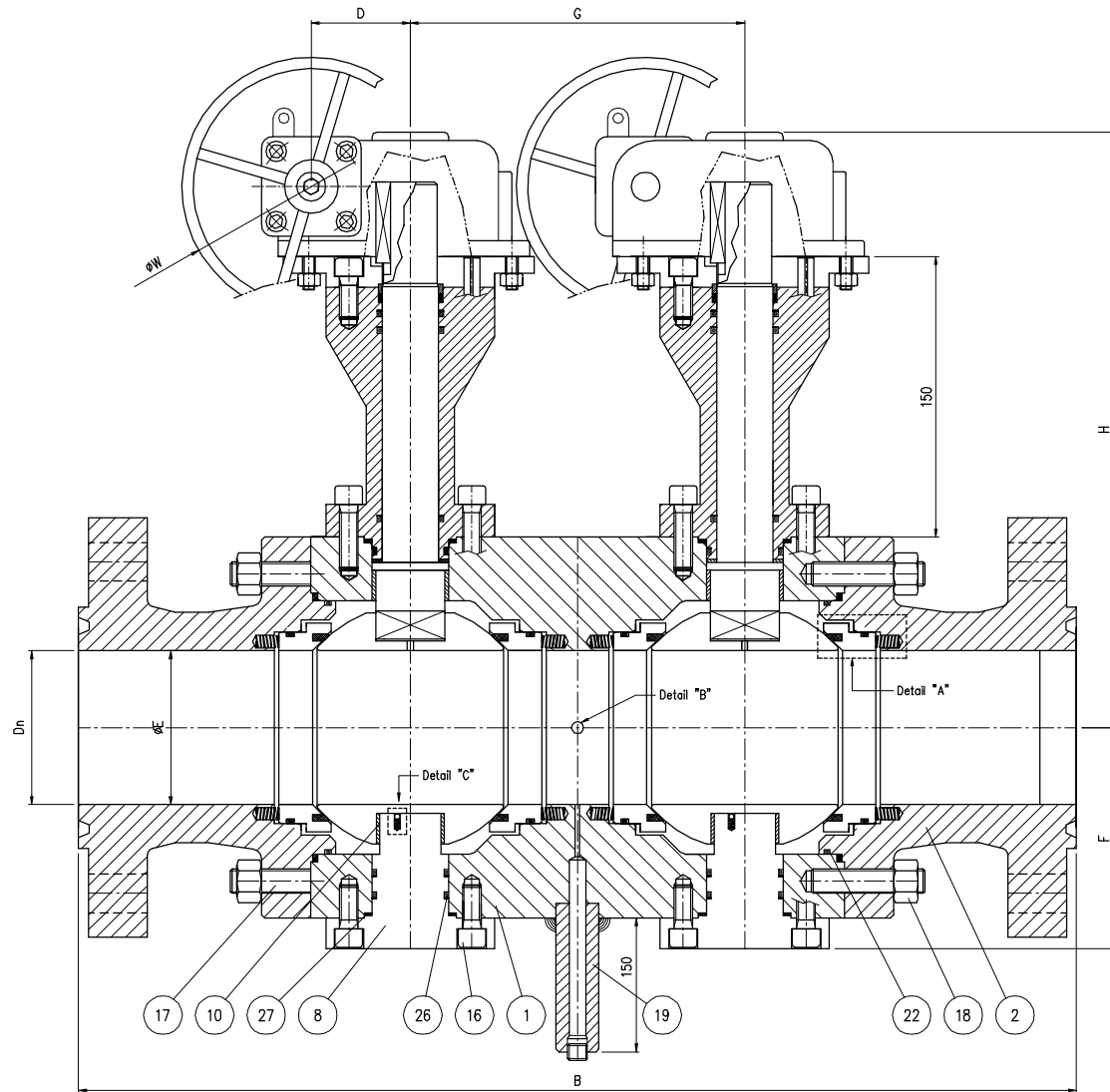

		Dwg. N° VT2-23615-D	
		<small>           Dwg. D.R. Date 10.01.09            App. D.R. Date 12.01.09            Draw. AS Scale 1:1            Des. D First Issue            Rev. 0 First Issue            Rev. 1 First Issue         </small>	<small>           Dwg. D.R. Date 10.01.09            App. D.R. Date 12.01.09            Draw. AS Scale 1:1            Des. D First Issue            Rev. 0 First Issue            Rev. 1 First Issue         </small>
Denomination <b>Ball Valve "Side Entry" Trunnion</b> <b>Dn 2"-3" Class 600 - 1500 RTJ DB&amp;B</b>		<small>           12 D.R. 21.09.11 D.R. 22.11.11 AS Gear            11 D.R. 15.05.11 D.R. 15.12.11 AS Gear            Rev. 01 Date App. Date Description Review         </small>	
Component <b>Overall Dimension</b>			